

Miniature Bending Beam



FEATURES

- Capacities: 50, 100, 150, and 250lb
- Low profile for low capacity scales
- Electroless nickel plated alloy tool steel

OPTIONAL FEATURE

- FM approval available

DESCRIPTION

MBB is designed for low profile platform scales and tank scales in low capacities. It is constructed of high alloy tool steel which offers superior performance in creep characteristics and shock load capabilities over standard aluminum units.

MBB is fully potted and sealed with special chemical compounds to IP66 providing

excellent protection against moisture and humidity.

APPLICATIONS

- Silo / hopper / tank weighing
- Packaging machines
- Dosing / filling
- Belt scales / conveyor scales

OUTLINE DIMENSIONS

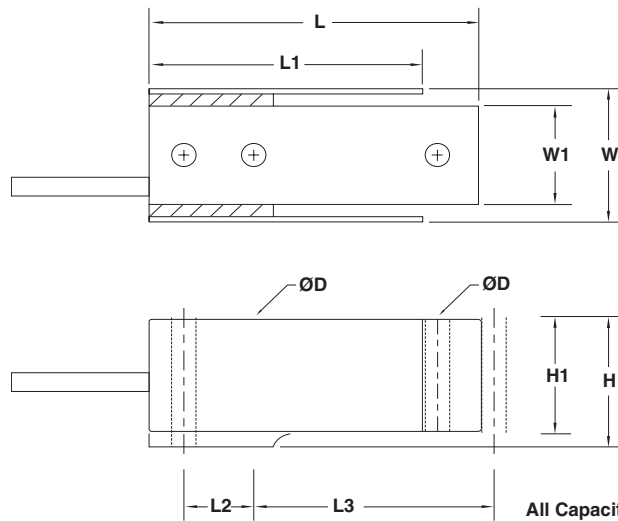

Wiring diagram

- + Excitation Red
- Excitation Black
- + Signal Green
- Signal White

All Capacity
Cable Length: 5' / 1.5m

CAPACITY		L	L1	L2	L3	W	W1	H	H1	D1	D	T
50/ 100/ 150lb	mm	60.3	50.3	12.7	33.7	19.1	12.7	24.8	22.2	4.4	4.4	----
	(inch)	2.37	1.98	0.50	1.33	0.75	0.50	0.98	0.87	0.17	0.17	
250lb	mm	60.3	50.3	12.7	33.7	25.4	19.1	24.8	22.2	4.4	4.4	----
	(inch)	2.37	1.98	0.50	1.33	1.00	0.75	0.98	0.87	0.17	0.17	



SPECIFICATIONS

PARAMETER	VALUE	UNIT
NTEP/OIML Accuracy class	Non-Approved	
Maximum no. of intervals (n)	3000	
$Y = E_{max}/V_{min}$	5000	Maximum available
Standard capacities (E_{max})	50, 100, 150, 250	lbs
Rated output-R.O.	3.0	mV/V
Rated output tolerance	10	±% of rated output
Zero balance	1	±% of rated output
Non linearity	0.030	±% of rated output
Hysteresis	0.030	±% of rated output
Non-repeatability	0.020	±% of rated output
Creep error (20 minutes)	0.030	±% of rated output
Zero return (20 minutes)	0.030	±% of rated output
Temperature effect on min. dead load output	0.0026	±% of rated output/°C
Temperature effect on sensitivity	0.0015	±% of applied load/°C
Compensated temperature range	-10 to +40	°C
Operating temperature range	-20 to +60	°C
Safe overload	150	% of R.C.
Ultimate overload	300	% of R.C.
Excitation, recommended	10	Vdc or Vac rms
Excitation, maximum	15	Vdc or Vac rms
Input impedance	385±5	Ohms
Output impedance	350±3	Ohms
Insulation resistance	>5000	Mega-Ohms
Construction	Nickel plated alloy steel	
Environmental protection	IP66	

All specifications listed subject to change without notice.

FM Approval

Intrinsically Safe: Class I, II, III; Div. 1 Groups A-G

Non-Incendive: Class I; Div. 2 Groups A-D